

# MYTORQ

## **IMPACT SERIES Cordless Screwdriver OPERATION AND MAINTENANCE MANUAL**

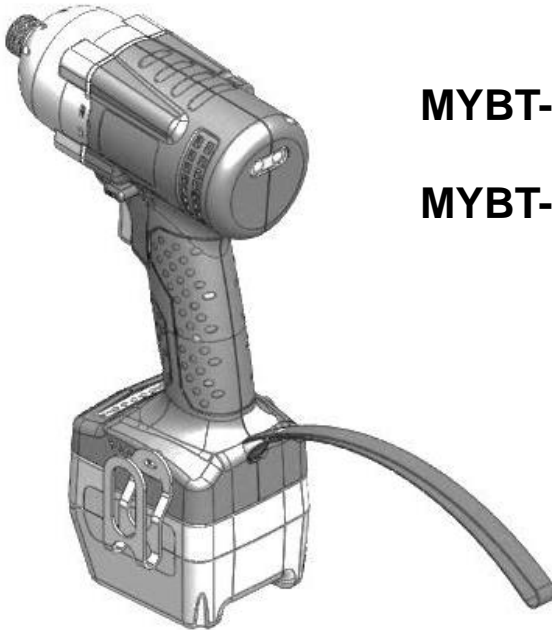

**MYBT-IM50**

**MYBT-IM100**

**ANLIDAR INDUSTRIAL CO., LTD.**

**<http://www.anlidar.com>**

Y2F135A-2E-001

Please read manual carefully before operating the rechargeable impact screwdriver.

## Icon Instructions

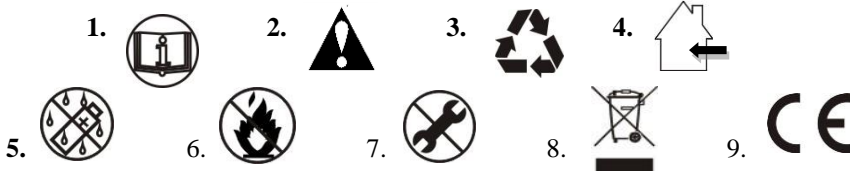

1. Read instruction manual.
2. Observe caution and safety notes.
3. Recyclable.
4. For indoor use only.
5. Do not expose to wet or rain conditions.
6. Do not operate in an explosive atmosphere.
7. Do not disassemble.
8. Forbid throwing.
9. CE Certificate.

## Accessories

Item	Quantity	Unit
Manual	1	PCS
Guarantee Card	1	PCS
S Waist Hook	1	PCS
Screw M3*0.5P*10LT	1	PCS
Socket Extension (B)	1	PCS
BIT(B)	2	PCS

## Warning

Read all instructions and make sure the appearance of the device has no damage before you use it. Failure to follow all instructions listed below may result in electric shock fire and/or serious injury.

1. Keep the working area nice and clean.
  - 1.1 Mess and dark areas may cause of accidents.
  - 1.2 Keep the device away from rain or moisture to decrease the risk of electric shock or short-circuiting occurred.
2. Be alert to workplace safety
  - 2.1 Use the device under a well lit and clean environment.
  - 2.2 Keep children and other people away unless the person has been assigned for the task to avoid the danger of injury.
  - 2.3 Do not play around while the tool is being used to avoid the danger of distractions.
  - 2.4 Do not work with the device in potentially explosive environments in which there are inflammable liquids, gases or dusts. Electrical power tools create sparks, which can ignite dusts or fumes.
  - 2.5 Do not use the device if you are tired or under the influence of drugs, alcohol or medication.
3. When the devices are not being used, store them in a safe place.
4. Use a suitable device for the job will be safer at work and have a better result.
5. Always use a screwdriver that is intended for the task you are undertaking. Do not overload or use it improperly such as drilling or tapping.
6. Dress properly. Do not wear loose clothing or jewels while operating the tool to avoid the danger of trapping.
7. By using the device correctly, make sure to hold it firmly with two hands in place before starting the trigger.
8. When using the electrical power tool, take into account the auxiliary handle or waist hook is advantage of working conditions. On the contrary, the purposes of the waist hook or driver hook is convenient to put the device away and easier to keep it out of reach of children.
9. Look after either the device or the battery carefully and have any damaged parts repaired by an authorized or qualified shop. Always keep the tool nice and clean; pay attention on the machine grease which might ruin the tool.
10. Disconnect the plug from the power source after the charger has been used.
11. Take apart the battery from the device when it is not being used.
12. Use only the accessories that are detailed in the operating instructions. The use of others which are not recommended in the operating instructions may affect the functioning of the device. It could lead to an increased risk of personal injury as well.
13. Remain alert at all times and watch what you are doing during proceeding. Before operation, always check every part is in good condition and move freely in order to function properly.
14. This device only applies for metal screw bits designated with their dimensions and their shape. Do not recommend to countersink or force of loading on any material such as plastic and wooden.
15. The device does not apply for elastic or tensile load with washer on.
16. To prevent parts in gearbox from damage, replace the grease at least once for every year.
17. It is necessary for the operators to read and follow up all the operating instructions in this manual. ANLIDAR is not responsible for any personal injury that might cause of disobeying the safety advices.
18. Use a safety device. Wear protective earmuffs to reduce personal injury.

## Function of Cordless Protection

- |                                    |                              |
|------------------------------------|------------------------------|
| ■ Over electric current protection | ■ Prevent from low power     |
| ■ Thermal Protector                | ■ Stall protection           |
| ■ Slow rotation protection         | ■ Reverse control protection |
| ■ Battery Identification           | ■ Sleeping mode              |

## Warning

 **Do not attempt to repair or disassemble this cordless screwdriver, the warranty will be considered void.**

1. Make sure to remove the battery pack before maintaining or repairing the device by a qualified technician.
2. Do not attempt to disassemble or reassemble the device at will which may result in poor performance or danger of injury, the warranty applies only to initial package.
3. Do not repair the device with other than genuine MYTORQ replacement parts may result in poor performance or danger of injury, the warranty will be considered void.
4. The temperature between 0°C ~35°C would be an ideal condition of carrying out the tasks on the device.

## Operation Cautions

1. Charge the battery in the charging station before first use to make sure operates at its highest capacity. To ensure operators against injuries, release the forward/reverse lever as arrow showing below into a center position to have trigger locked before start or disassemble the device.

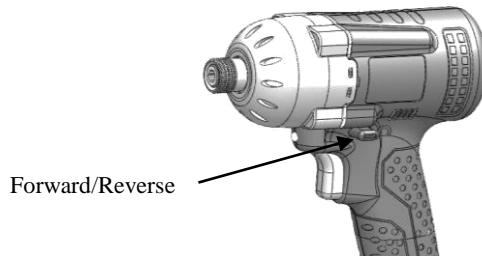

- 2.1. Below illustration is showing the process of correct install & disassemble the rechargeable battery. The beep sound comes along with a flash while the screwdriver is supplied genuine battery installation. It could be operated once the battery has been identified.

2.2. Too slow to install the battery may cause error identification so the beep sound and flash would be continuing. In order to function properly, re-assembling it as below process again.

## Insert Battery Steps

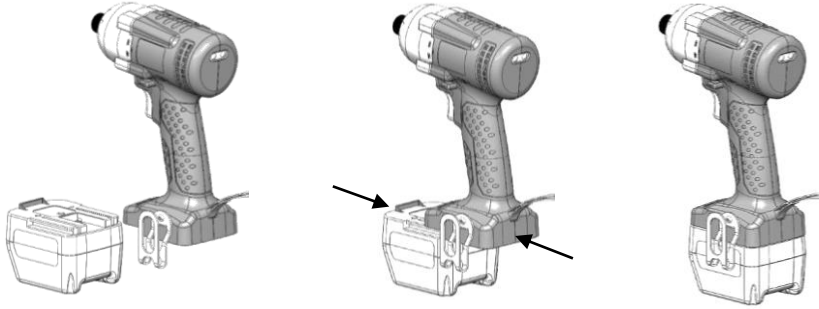

(1) Insert the rechargeable battery into the device follow by the arrow as showing.

(2) Assembled completely.

## Remove Battery Steps

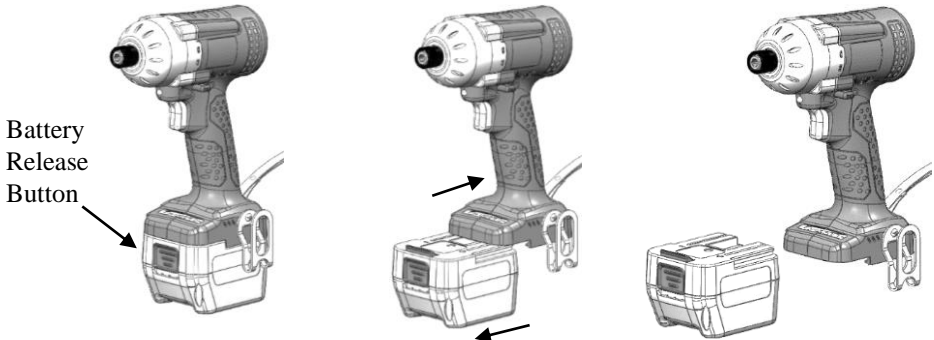

(1) Press the release button and take it out of the device.

(2) Follow the arrow direction.

(3) Removed completely

## Appearance Functions Introduction

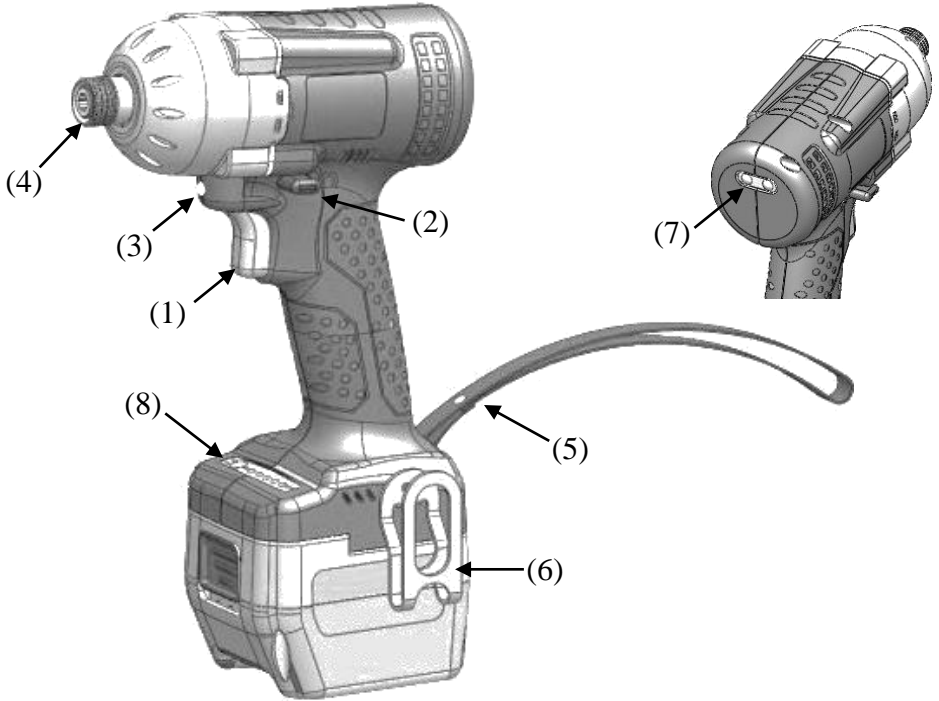

Function Name Table

No.	Description	No.	Description
(1)	Trigger Switch	(5)	Wrist Strap
(2)	Forward/Reverse Lever	(6)	S Waist Hook
(3)	LED Light	(7)	Indication Light
(4)	Bit Sleeve	(8)	Torque Adjustment Light

## Manual / Functions



### 1. Impact cordless screwdriver

Screws are continually fastened up while come along with clutch PA-PA-PA sound until the device reaches of Five control the stop time.

#### (1) Trigger switch

The LED lights on when the trigger switch has been pressed about one-third down, and then the screwdriver starts functioning when the switch trigger has been pressed half way down; on the contrary, it stops when the screw has been tightened up or the trigger has been released.

#### (2) Forward/Reverse Lever

When push the Forward/Backward switch to the right. According to the symbol  on the switch, the screwdriver rotates clockwise and tightens the screws. When push the switch to  the screwdriver will rotate anti clockwise and loosen the screw. When the screwdriver is idle, set the Forward/Reverse switch in the middle.

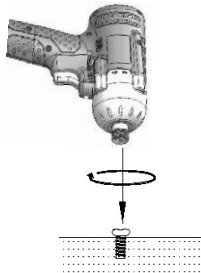

**Forward (screw)**

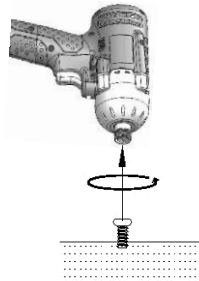

**Reverse (unscrew)**

#### (3) LED light

While press the trigger, the LED lights up automatically to assist the job to be done; on the contrary, it will be off once the trigger has been released.

#### (4) Bit sleeve

Switch the screw bit and compatibility, pull the head of the type B screwdriver, and install the bit according to the diagram below, after installing the bit please also install the Socket Extension Insert the sleeve and push it in following the arrow indicated on the diagram below on Diagram 2.

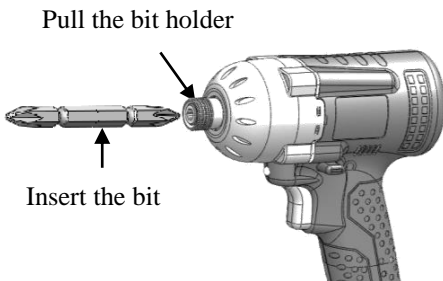

**Diagram 1**

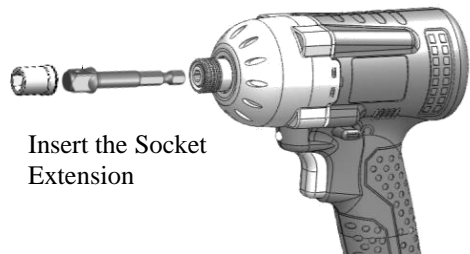

**Diagram 2**

(5) Wrist Strap

Use Wrist Strap with tool for more convenient and safer operation and store.

(6) S Waist Hook

Use S Waist Hook to fix tool for more convenient and safer operation and carry.

(7) Buzzer beep and LED light Indication Light:

Operation status	LED Lights	Buzzer Beep
Voltage 17V~17.5V	Red light flashing continue	Beep continue
Voltage under 17V	Red light continue	2 short and 1 long Beep continue
Torque reached stop	Green light flashing 1 time	Beep 1 time
Over current protection	Red light flashing 6 times	Beep 6 times
Over temperature protection	Red light flashing 9 times	Beep 9 times
Low rpm protection	Red light flashing 3 times	Beep 3 times
Stall protection	Red light flashing 3 times	Beep 3 times
Battery ID error	Red/Green light flashing continue	Beep continue

(8) Torque Adjustment Light: Five sections Bit torque setting

- 1). Will Forward/Reverse Lever Cut to the middle position °
- 2). Pressing a bit start switch button at the Wake screwdriver °
- 3). Pressing Torque Adjustment Light Approximately 5 seconds, Torque identification light starts flashing, then press the torque adjustment knob to adjust the desired torque.
- 4). Adjust the desired torque, Pressing Torque Adjustment Button Approximately 5 seconds., LED stops flashing and at Approximately 5 seconds after the off, adjustment is completed.
- 5). Confirm torque, turn the switch to the forward or reverse position, then press the trigger switch to view the torque light is lit selected by you.
- 6). Torque light as illustration, the left most light means min. torque output, then the torque output increases gradually from left to right, the light of right most means max. torque.



2. Please pay attention when operating the rechargeable screwdriver. Do not drop or abuse the screwdriver.
3. Not allow to turn the switch during operation in order to cause system malt-function.
4. During operation, the Forward/Reverse switch has been changed accidentally that the device will enable its self-protecting mode which is power off. Re-start the tool when this happen.
5. When switches Forward/Backward switch during the screwdriver still operating, the protection mechanism will be triggered and cause the motor to stop. Restart the screwdriver again will change back to normal.
6. Each operational torque setting, using time and frequency may result in different level of wear and tear, at higher torque setting and use extensively could accelerate the wearing down of tool. After one month, the torque is getting reduce gradually at the rate of 2~3% or 3~5 % ( max torque). The longer use of the device, torque reduction will become stable and the users could measure the torque by a tester on a regular time schedule to check if the torque power still meets the criteria.

## Other Cautions

1. The best condition of using the tool is under 8 hours a day, do not over loaded.
2. Do not attempt to repair or disassemble this cordless screwdriver without authorization. Always have the device serviced by assigned factory or qualified person in order to have the warranty effective continually.
3. ANLIDAR is not responsible for any poor performance or damage caused by customers own modification of the tool.
4. It is necessary for the management to have individual operators read and follow up all instructions in this manual. Do not attempt to repair or disassemble this cordless screwdriver themselves.
5. Removing protection cap by pry open the slots located on both side of the screwdriver as indicated in the diagram 1 below. To install the protection cap, the cap gap facing downward and push it into the slots. As indicated in the diagram 2 below.

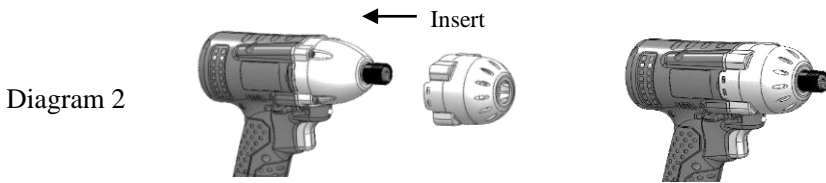

6. The torque measuring of MYBT-IM100 is completed by SKIDMORE-WILHELM model J bolt tension calibrator.

## Description of battery and charger

1. ANLIDAR SKC-LB1820B series of battery as options to fit in the device; you may consult with local agent based on your task requirement.
2. The use of other than genuine ANLIDAR batteries or screwdrivers can't be active due to the build-in protection system enforce no charging.
3. MYCS-ID80-D charger with LED on is recommended.

## Warning beep sound

1. Screwdriver stops along with three warning beep occurs while the motor speed is lower than 1000 rpm.
2. PCB temperature detector preventing the screwdriver overheated; it stops along with three warning beep occurs while the PCB temperature is over 70°C.
3. Restarting the screwdriver which dismissing from a safety mood may come along with three beep sounds.

## Specifications

MODEL		MYBT-IM100	MYBT-IM50
Input Voltage		DC 18V	
Bit torque(N.m)	1	0~20	0~7
	2	0~40	0~15
	3	0~60	0~25
	4	0~80	0~35
	5	0~100	0~50
Rev speed at no load n0: (r/min) ±10%		0~2300	
Impact rate (B.P.M)		0~3000	
Weight (Kg)		1kg( battery not include )	0.9kg( battery not include )
Length (mm)		155 mm * 195mm ( L * H battery not include )	
Model of rechargeable battery		SKC-LB1820B	
Model of battery charger		MYCS-ID80-D	
Bit type			

**Bits Code** ~ W: square B: Hex 6.35mm

**Accessory** ~ B I T no. : NO.3# apply to 3.0~4.0mm

**CAUTION**   
**KEEP THESE INSTRUCTIONS**  
**DO NOT DESTROY**