

Torque Display User Manual

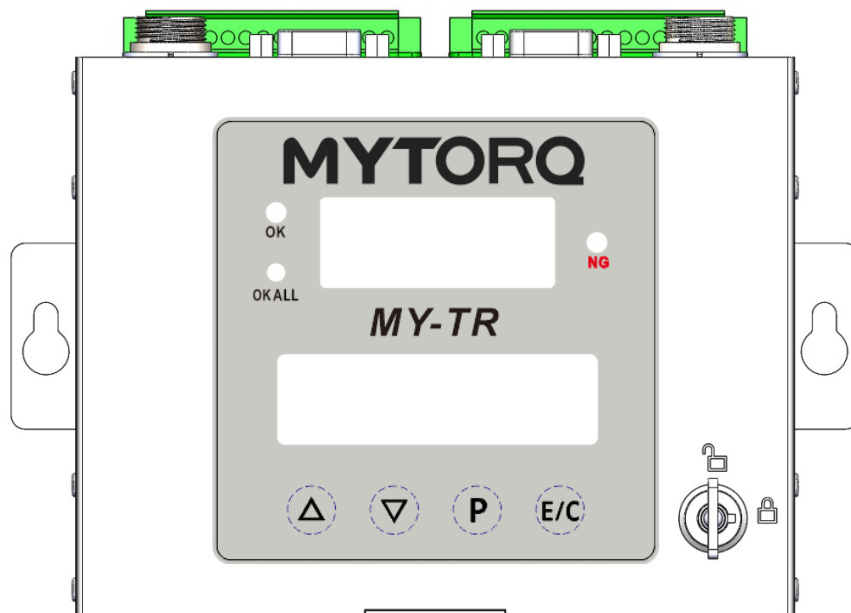

Model : MY-TR

(Ver 2.00)

SAING EI CORP.

<https://www.mytorqtools.com>



Y2F167-3E-019

20211201-V2129

1. Panel Function

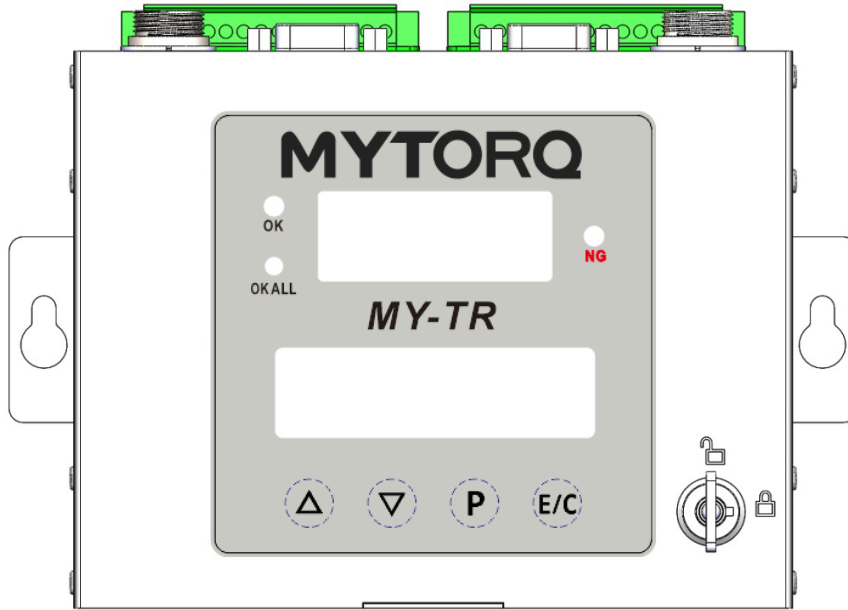

Display screen:

1. Four-digit seven-segment display of torque value
2. 16X2 LCM display setting function

C	:	9	9	T	:	9	.	9	9	9	9	.	9	
Q	:	5	5	0	.	0	0	K		O	K	A	L	L

- C: Display count value
- T: Display screwdriver action time
- 999.9 display number of turns
- Q: Display torque value
- S: Display status (OK, NGT, NGQ, NGC, OKALL....)

Up Key: Setting mode Up key switch function.

Down Key: Setting mode Down key switch function.

P key: Press three seconds to enter/leave the setting mode/ Clear Sequence.

E/C: Restore initial defaults/ Clear count value /CONFIRM.

OK, NG, OKALL: Display status indicator.

Key switch: Lock the key usage functions.

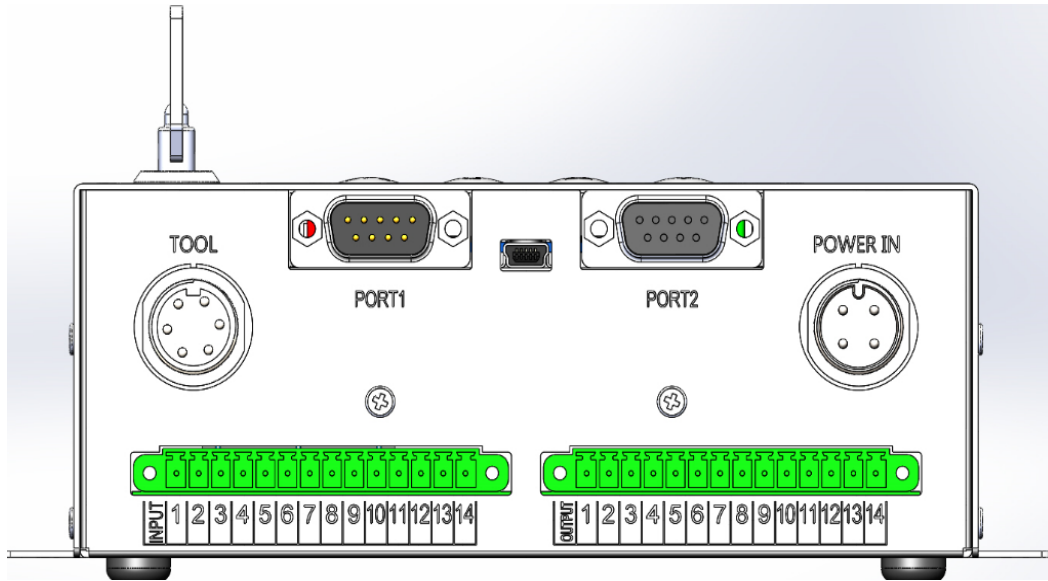

	Power port (4PIN)	Screwdriver port (6PIN)	RS232/PORT1	RS232/PORT2
small torque	MYP32-300N	Anti-interference cable	Connect Barcode Scanner	Connect DAS
power torque	MYP40-1500 MYP40-500 (MY8 series)	Anti-interference cable	Connect Barcode Scanner	Connect DAS
Remark: Please switch the power controller HI/LO switch to "HI" position.				

2. Set Function Options and Operating Instructions

After switching on the power, to enter into the function menu, press the “P” key on the panel for 3 seconds, following which password input is required to enter the menu.

Name	Set Up Time and Value	Function Interpretation	Factory Setting Value
[1]PROGRAM	1-99	Select program	1
BATCH COUNT	1-250	Set up count value Count number range is 1~250	5
TIME LIMIT	0.00-9.99 sec	Set up LT & HT functions LT: Setting time and value is 0.00-9.99, Screwdriver stops or shut off before Lo time setting, NG will be displayed on the status bar. It can check whether the screw is properly fastened or not. (Lo time setting can be used to detect cross threading or unfinished rundowns) HT: Setting time and value is 0.00-9.99, Screwdriver stops or shut off exceeded Hi time setting, NG will be displayed on the status bar. (Hi time setting can be used to detect stripped or oversize screw)	LT:0.00 HT:9.99
TORQUE LIMIT	0.0-550.00 KGF.cm	Set up L & H functions L & H: The options of Minimum Torque and Maximum Torque allow the user to set up the acceptable torque range for each independent application program. When the reaching torque is in the range, “OK” will be displayed on the status bar, and the green LED light is lit up. If the reaching torque exceeds such range, “Error in Minimum Torque” or “Error in Maximum Torque”, “NG” will be displayed in the status bar, and the red LED is lit up. The torque range value is 0-550KGF.	L:0.0 H:550.00

Name	Set Up Time and Value	Function Interpretation	Factory Setting Value
THREAD LIMIT	0.0-999.9 Turns	Number of screw turns L & H: The options of Minimum number of turns and Maximum number of turns allow the user to set up the acceptable number of turns range for each rundown. The actual number of turns measured refers to the motor turns/gear ratio; when the number turns reached the range, "OK" is displayed in the status bar, and green LED light of OK" is lit up. If the reaching number of turns exceeds such range, "Error in Minimum number of turns" or "Error in Maximum number of turns", "NG" will be displayed in the status bar, and the red LED is lit up.	L:0.0 H:999.9
SLOW START TIME	L0-L9/ 0.0-9.9 sec	Set up screwdriver slow start time and speed. S: Set up slow start speed level, L0 (100%), L1~L9 (10%~90%). (L0/L1/L2/L3/L4/L5/L6/L7/L8/L9) T: Set up slow start time, slow start time is 0.0-9.9 sec..	S:L0 T:0.0
AUTO FORWARD	RR:0.00-9.99 sec RS:0.10-9.99 sec	Set up screwdriver reverse start time, then pause RS time, followed by forward rotation until screwdriver shuts off. RR: Set up the screwdriver reverse start time RS: Set up the screwdriver pause time after reverse.	RR:0.00 RS:0.10
AUTO REV. TIME	0.00-9.99 sec	Automatic reverse. Set up auto reverse time after screwdriver shut off.	0.00
AUTO STOP TIME	0.0-9.9 sec	Set up pre-fastening time.	0.00
RECONFIRM TIME	0.00-9.99 sec	Set up re hit time after rundown complete.	0.00
ALARM SG. TIME	0.00-9.99 sec	AT: OKALL signal output time OT: OK signal output time	AT: 1.00 OT: 0.00
NS STOP	ON/OFF	Set up the handling method selected during errors of the screwdriver. Set up for ON: when there is error signal, display NS stops the action of the screwdriver immediately. The user is required to press the "E/C" key for confirmation in order to unlock the forward rotation (For I/O control, input "CONFIRM" from the external confirm key; however, the screwdriver can perform reverse rotation). Set up for OFF: when there is error signal, the screwdriver will not be locked, and it will not affect the switch-on of the screwdriver next time, but only a warning is sounded.	OFF
AS STOP	ON/OFF	Set up handling method selected during the action completion of count value. When the action is complete, the user is required to press the "E/C" key for confirmation in order to unlock the forward rotation (for I/O control, input "CONFIRM" from the external confirm key). Set up for OFF: when the action is complete, the screwdriver is not locked, and it will not affect the next switch-on of the screwdriver.	OFF
TORQUE OFFSET	±0.0-400.00 KGF.cm	Set up the torque compensation value, the torque output displays the value after compensation.	±0.0
COUNT THREAD	0-255	Thread Setting Set the thread value according to each electric screwdriver model	10
[2] TOOL INFO	1 (Automatic access and saving)	Tool sequential number.	1
GEAR RATIO	1-99	Set up the gear ratio and set up such value according to each electric screwdriver model.	14
SCREWDRIVER ID	Tool product serial number	Tool product serial number. Before the tool exit the factory (electric screwdriver), the factory provides the tool a serial number. When equipment (MY-TR) needs to be replaced, the tool serial number can be searched from the equipment end.	Tool product serial number

Name	Set Up Time and Value	Function Interpretation	Factory Setting Value
ALIGNMENT TIME	XXXX/00/00 00:00	Record calibration date and time.	XXXX/00/00 00:00
TORQUE FILTER	0-250、 UNLIMITED	Torque Filter Function : 0 : Disable Filter 1 - 250: Enable Filter Counter UNLIMITED : Infinite filtering	0
[3]DEVICE ID	1-255	Equipment No.	1
DEVICE SN	Product serial number	Display serial number of product	Product serial number
DEVICE TIME	XXXX/00/00 00:00	Device time	2017/01/01 00:00
REVERSE MODE	ONCE /EACH	Set up reverse rotation deduction function. ONCE : reverse rotation only counts down once only. EACH: count down each reverse rotation	ONLY
BATCH MODE	INC/DEC	Set up count number function. INC: count up, DEC: count down	INC
BRAKE SIGNAL	RELEASE/KEEP	Brake signal method. When it is RELEASE . After screwdriver triggered and shut off, brake signal will last until trigger released. When it is KEEP . After screwdriver triggered and shut off, brake signal will last until next time screwdriver triggered.	RELEASE
THREAD FINDING	ON/OFF	ON: NG will not display when no load rotation OFF : NG will display when no load rotation	ON
GATE MODE	OFF/ONCE/TWICE/ ONCE+CON/TWICE +CON	ONCE: workpiece in position at once TWICE: workpiece in position at two times ONCE+CON: workpiece at position at once plus CONFIRM for confirmation TWICE+CON: workpiece at position at two times plus CONFIRM for confirmation	OFF
TORQUE UNIT	kgf.cm/N.m/ lbf.in/kgf.m	Set up torque display unit.	kgf.cm
OPERATION MODE	STD/ADV	Connection mode. STD: Standalone mode. ADV: KL-AMS network system (WIFI/Ethernet) connection mode.	STD
TORQUE ALIGNMENT	ON/OFF	Calibration torque switch on/off Press E/C key to start selection, use Up and Down key to change to ON, and then press E/C key to confirm.	OFF
SEQUENCE SET	OFF/MULTI/SINGLE	OFF: Disable MULTI : A Job cycle SINGLE : Sequence cycle	OFF
POO- POO-... *8	P01-99	Sequence order	0
AUTO LEARNING	ON/OFF	Automatic learning. Turn on auto-learning function; wait for the auto-learning to complete (need to perform brake function), monitor will then display the screw driving time, torque value, number of screw turns, and such data will be saved. Above data cannot be 0 in order to save the parameters after the auto-learning.	OFF
BCODE LEARNING	ON/OFF	First Code G1-G5 : Set Barcode group Second Code P1-P99 : Set PROGRAM Group CL : Clear DA : Disable Screwdriver Functions EA : Disable Relieve AS : Release Screwdriver lock status by OKALL NS : Release Screwdriver lock status by NG	G1-P1 The maximum length of Barcode data is 16 characters

Name	Set Up Time and Value	Function Interpretation	Factory Setting Value
[4]PASSWORD	A0000	Set up password lock.	A0000
CONTROL VER.	V2.XXX	Mainboard version.	V2.XXX
SCREWDRIVER VER.	V2.XX	Screwdriver version.	V2.XX

Action Limitation				
	RR/RS	RT	PT	LL
AUTO FORWARD (RR/RS)	V	X	X	X
AUTO REV. TIME (RT)	X	V	X	X
AUTO STOP TIME (PT)	X	X	V	X
RECONFIRM TIME (LL)	X	X	X	V

Remarks: V - setting available, X - OFF

3. Set function options and operating instructions

3-1. After the power is turned on, press the "E / C" button for 3 seconds to enter the menu of initial default, which must enter the password to enter.

LOAD DEFAULT	NO/DEFAULT	Cancel/restore to factory setting	NO
--------------	------------	-----------------------------------	----

3-2. The status "LC" is displayed on the 7-segment display when key lock has been used.

Un: Key of unlock state	LC: Key of lock state
-------------------------	-----------------------

3-3. After the power is turned on, press the "P" button for 3 seconds to enter the Function menu page, which must enter the password to enter.

3-4. After enter the function menu page, parameter can be browsed and setting by press up and down button.

4. External Input Co4. External Input Control Function Description

Connector No.	Definition	Function Description
CN 1	External start signal input START_IN	1. When (CN1+GND) is in close circuit (CLOSE), the screwdriver then Starts. 2. When (CN1+GND) is in open circuit (OPEN), the screwdriver then Stops.
CN 2	GND	Output GND.
CN 3	External reverse rotation signal input REVERSE	1. External switch-on (CN1) is in close circuit with GND (CLOSE); during the reverse rotation signal (CN3+GND) Close (CLOSE), the screwdriver then starts the activation of Reverse rotation. 2. External switch-on (CN1) is in close circuit with GND (CLOSE); during the reverse rotation signal (CN3+GND) Open (OPEN), the screwdriver then starts the activation of Forward rotation.
CN 4	GND	Output GND.
CN 5	External disable signal input DISABLE	1. When (CN5+GND) is in close circuit (CLOSE), the screwdriver cannot be activated. 2. When (CN5+GND) is in open circuit (OPEN), the screwdriver can be activated.
CN 6	GND	Output GND.
CN 7	External confirm key input CONFIRM	1. When the system requires the press of confirmation key, the CN7 in close circuit with GND can be used instead. 2. After executing the CONFIRM, the NG signal is also cleared.
CN 8	GND	Output GND.
CN 9	External confirm key input CLEARED	To clear the count value, the CN9 in close circuit with GND can be used to clear count value.
CN 10	GND	Output power GND.

CN 11	External sensor switch GATE	1. Input a confirmation signal to allow the controller to determine that the workpiece is in position. 2. Sensor switch: external switch in operation can be connected to one or two switches. 3. Connection to any switch shall be connected to GND (CN14).
CN 12	GND	Output GND.
CN 13	SEQUENCE CLEARED	When the sequence is to be cleared, this function can be triggered by CN13 to GND connected. (CN13+GND)
CN 14	GND	Output GND.

5. External Output Control Function Description

Connector No.	Function Description	Remarks
CN 1	START	RUN FWD: During the switch-on of screwdriver, CN1, 2 are conducted During close circuit, CN1-CN2 are conducted During open circuit, CN1-CN2 are disconnected
CN 2	COM	GND: This pin refers to the RUN FWD signal connection negative end
CN 3	BRAKE	Brake: When the brake of the screwdriver is actuated, CN3, 4 are conducted During close circuit, CN3-CN4 are conducted During open circuit, CN3-CN4 are disconnected
CN 4	COM	GND: This pin refers to the Brake signal connection negative end
CN 5	REVERSE	RUN BWD: Reverse triggered by conducting CN5 and 6 During close circuit, CN5-CN6 are conducted During open circuit, CN5-CN6 are disconnected
CN 6	COM	GND: This pin refers to the RUN BWD signal connection negative end
CN 7	OK	OK: After completion of fastening a screw, CN7 and 8 are conducted During close circuit, CN7-CN8 are conducted During open circuit, CN7-CN8 are disconnected
CN 8	COM	GND: This pin refers to the OK signal connection negative end
CN 9	NG	NOK: When there is an error operation, CN9 and 10 are conducted During close circuit, CN9-CN10 are conducted During open circuit, CN9-CN10 are disconnected
CN 10	COM	GND: This pin refers to the NOK signal connection negative end
CN 11	OKALL	OK BATCH: When the batch completed, CN11 and 12 are conducted During close circuit, CN11-CN12 are conducted During open circuit, CN11-CN12 are disconnected
CN 12	COM	GND: This pin refers to the OK BATCH signal connection negative end
CN 13	24/12Vdc	Controller output voltage: DC+12V/100mA or +24V/50mA Default value: +24V/50mA (+12V/100mA can be customized).
CN 14	GND	Output GND.

※Notification :

1. INPUT Contact , If a non-isolated (wet contact) control method is used, a 10K resistor must be connected in series on the circuit.

2. When installing an automated machine, it is recommended to first install the signal cable at the machine end and then connect it to the MY-TR.

When collaborating with automated controls, please notes to the above items to prevent equipment damage.

6. CONFIRM Mode

Code	Description	Remarks
C1	Refers to a switch SENSOR confirmation method	External sensor switch
C2	Refers to two switch SENSORS In case of errors, SENSOR needs to be in detection, and the panel displays “Er”; the “CONFIRM” on the panel needs to be pressed again or the external confirmation (CN7+CN8 close circuit) in order to clear the “Er”	External sensor switch
C3	Manual confirmation method for CONFIRM on panel	Panel/external CONFIRM
C4	Refers to switch SENSOR long ON confirmation method + manual confirmation of CONFIRM on the panel or external confirmation (CN7+CN8 in close circuit) method.	External sensor switch + external CONFIRM
C5	Refers to two switch SENSOR confirmation method + manual confirmation method of CONFIRM on the panel or external confirmation (CN7+CN8 in close circuit).	External sensor switch + external CONFIRM

7. ERROR CODE Mode Status Description

Code	Symbol Definition	Function Description
E3	Voltage-drop protection	When the voltage of the electric screwdriver drops instantly, the action of the electric screwdriver is stopped, and the LED displays this symbol, representing that the screwdriver is currently under low-voltage protection.
E4	Over-temperature protection	When the internal temperature of the electric screwdriver is too high, the action of the electric screwdriver is stopped, and the LED displays this symbol, representing that the screwdriver is currently under over-temperature protection.
E5	Rotation-jamming protection	When the startup of the electric screwdriver motor is abnormal, the action of the electric screwdriver is stopped, and the LED displays this symbol, representing that the screwdriver is currently under motor startup abnormality protection.
E7	Direction push board abnormal	When the electric screwdriver motor is switched on, as the direction push board is changed, the motor of the screwdriver then stops action immediately, and LED displays this symbol.
E8	Brake signal abnormal	When the electric screwdriver brake signal detection is abnormal, the action of the electric screwdriver is stopped, and the LED displays this symbol.
ES	Screwdriver end communication abnormal	When the power screwdriver communication signal detection is abnormal, the action of the electric screwdriver is stopped, and the LED displays this symbol.
ESC	Screwdriver end calibration abnormal	When the electric screwdriver is not calibrated, the LED displays this symbol.
EPC	System end communication abnormal	ADV MODE communication detection abnormal.

8. Status Description

Code	Description
OK	Each time when the fastening is complete, LCD monitor displays OK.
OKALL	Each time when a batch is complete, LCD monitor displays OK ALL.
NS	When there is an error in open the rotation, LCD monitor displays NS. At this time, it needs to go through the Confirm/Enter key process in order to start next action.
NG	NGT: After the start of the screwdriver, the stop time is earlier than L/ later than H. NGQ: After the start of the screwdriver, the stop torque is earlier than L/ later than H. NGC: After the start of the screwdriver, the stop number of turns is earlier than L/ later than H. NG : When the THREAD FINDING function is off, it will show NG if rotate with no load has been detected.
Dis	The LED screen displays Dis when the External input, Communication protocol, and BCODELEARNING are disabled.

9. BARCODE instructions:

9-1. Hardware description

Connect Bar code Reader to port 1 on MY-TR through RS232

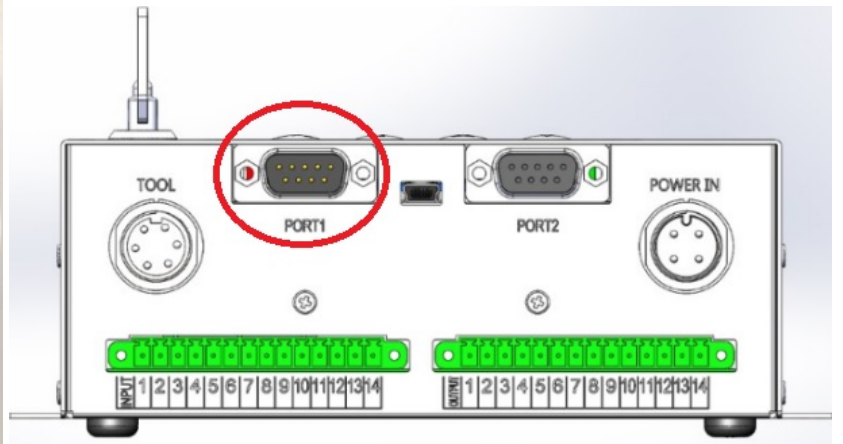

9-2. Barcode Reader Set function options

< Serial interface >

Record Suffix

====>CR

Baud Rate

====>9600 BPS

< Data Frame >

Data Bits

====>8

Parity

====>None

Stop Bits

====>1

9-3. Operation function description**9-3.1. Set fasten program command on MY-TR first**

The program that can be used to switch the fasten program through Barcode Reader

Use MYTORQ barcode for Program switching, 1-99 groups can be switched (CMD.P01-CMD.P99)

**Instructions:**

99 sets of programs have been preset on the MY-TR. The barcode of the group to be used must be pasted on the workpiece in advance. (eg: CMD.P01~CMD.P99)

When the workpiece comes in for fastening purpose, you need to scan the workpiece or pre-prepared barcode before the tool can be used and switch to the correct group.

9-3.2. Barcode Reader can be used for cancels the AS confirmation command. When the workpiece fasten batch is completed and AS is set, Barcode Reader can be used for cancels AS confirmation.

Use MYTORQ bar code format : CMD.C01 release AS (OkAll Stop)

**Description:**

The AS function has been enabled on the MY-TR. When an AS occurs, the screwdriver locks out and cannot be used.

The operator can use Barcode Reader to scan the prepared command bar code to release it for easy operation.

9-3.3. Barcode Reader cancels the NS confirmation command. When the workpiece fastening condition is wrong and NS is set, you can use Barcode Reader to release it.

Use MYTORQ bar code format : CMD.C02 release NS (Nok Stop)



Description:

The NS function has been enabled on the MY-TR. When an NS occurs, the screwdriver locks out and cannot be used.

The operator can use Barcode Reader to scan the prepared command bar code to release it for easy operation.

Warning

- 1 ∙ Please use entire set of special electric screwdriver with MY-TR
- 2 ∙ The MY-TR should be used with MYTORQ's power supply, electric screwdriver and accessories. SAING EI would not responsible for if it used with a non- MYTORQ screwdriver or spare parts for repair purpose, caused malfunction or poor quality resulting in failure of all guarantees.
- 3 ∙ SAING EI shall not be responsible for if used with non-MYTORQ screwdriver or power supply on MY-TR and use non- MYTORQ original spare parts repair, resulting in MY-TR failure or poor quality resulting in all guarantees of failure.
- 4 ∙ Please do not modify the connection ports and contacts to avoid malfunctions or poor quality and confirm with the SAING EI r before you try to change or modify any of them. Please be noted that all the guarantees will be invalid if you change the ports and contacts without authorization. SAING EI will not responsible for it. Electrical specifications of the IO port: INPUT: +48V, OUPUT: +48V/0.2A.

Operation Instruction

- 1 ∙ Please grasp the plug portion of the cable tightly when inserting or unplugging the power code connector of the screwdriver.
- 2 ∙ Do not pull the cable tightly, place it close to oil, chemicals, or hot objects. Also, be careful not to scratch the cable to sharp objects during operation.
- 3 ∙ The MY-TR can only be used exclusively for MYTORQ power supply, electric screwdriver and accessories. Do not use the electric screwdriver driver for other machines.
- 4 ∙ If the MY-TR overheats occurred or the load current exceeds the maximum rated current of the fuse, the quick type fuse will blow automatically cut off the power supply; please immediately stop operation as abnormal condition occurred such as continue fasten shut-off or the switching power, and the MY-TR and electric screwdriver is required return for repair service.
- 5 ∙ Do not disassemble the screwdriver of the electric screwdriver to try to fix it.
- 6 ∙ When not in use, please turn the main power switch to “OFF” position and unplug the power plug.

Grounding instructions

The electric screwdriver, MY-TR and power supply should be grounded to prevent the operator from getting an electric shock. The controller is equipped with three wires and three-pin grounding plugs for grounding sockets. The grounding wire of the socket itself must be connected to the ground wire of the power supply device. The yellow-green wire of the wire is the ground wire. Do not connect this yellow-green wire to an energized connector. The grounding wire in the controller is not only grounded for safety leakage, but also the ESD static as electricity generated when the driver works can be grounded by grounding.

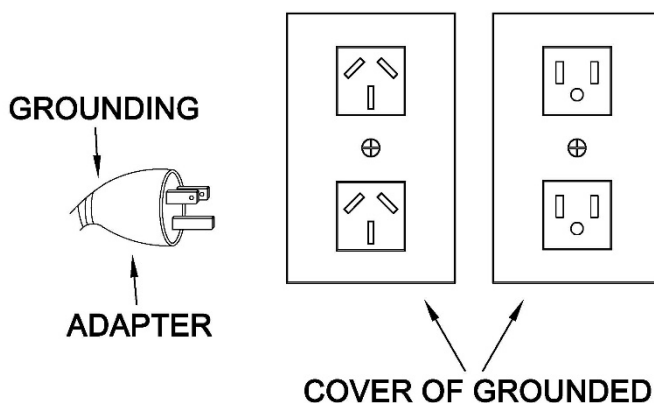

1. Controller power on and time synchronization

After controller is power on, it will send data {REQ0...} each second to inform external device such as computer、PLC、AMS. It needs to reply {CMD0,...} that controller function normally and controller time.

If the controller does not receive {CMD100,...},{REQ100,...}will be sent again after 10 seconds.

2. When controller received barcode information, it will send scanned data and data format as {REQ1....} to external device for control judgement or record saving. External device needs to reply {CMD0....}
3. After controller is power on and screwdriver shut off, brake signal format as {DATA0,} will be send. Every shut off will cause column 6 (no. of total tightening on controller) to increase by 1. External device needs to reply {CMD0,...}, if not, CMD0 will keep on sending DATA0(only update date time) and column 6 (no. of total tightening on controller) value will remain unchanged.
4. Shut off data will be sent after each shut off. Use the column 6 (no. of tightening on controller) to judge if there it is a new shut off data or not.
5. When controller receive feedback and format as {CMD0,...} from external device, controller will resume to automatically send {REQ0,...} and be able to configure controller time.

6. Recommended software control flow as below:

P.S: The content of [CMD0] in flow as the below:

{CMD0,0,0,0,0,0,0,0,YEAR,MONTH,DAY,HOUR,MINUTE,SECOND,0000,000

0}

str8 0001~9999 YEAR

str9 01~12 MONTH

str10 01~31 DAY

str11 00~23 HOUR

str12 00~59 MINUTE

str13 00~59 SECOND

str14 0000-9999 Check Sum(year, month, day, hour, minute, and second plus sum)

str15 0000-9999 Key Code(Check Sum + 5438)

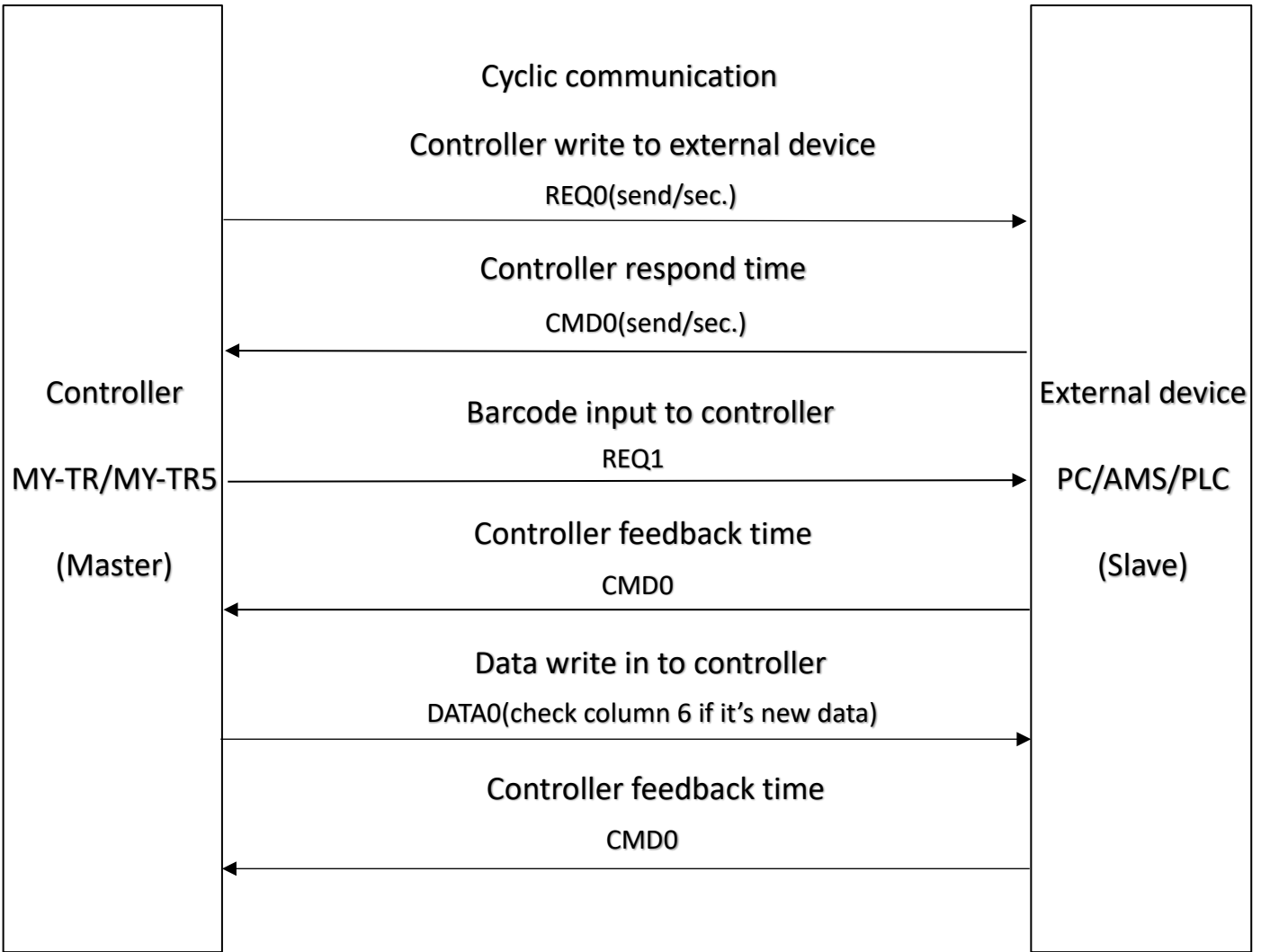

Our company reserves the right to modify the product without prior notice.

MYTORQ MY-TR 2.0 Basic Data Output Protocol Description

(Ver1.0 20210302_01)

COMPORT Setting: Baud rate : 115200/9600(MY-TR 1.7X), Data bit : 8 , Stop bit : 1, Parity bit :NON

Serial communication Mode -ASCII (American Standard Code for Information Interchange)

There are three basic data output formats send from device (MY-TR/MY-TR5) to external system (DAS/AMS/Other System) via the buildin RS232 port on the device :

- 1.Command {REQ0} : Send from Device to Host (Send device status to host per second after device startup ready)
- 2.Command {REQ1} : Send from Device to Host (Send barcode data to host immediately after barcode scanned a data)
- 3.Command {DATA0} : Send from Device to Host (Send last shutoff data to host immediately and repeat per second after screwdriver shutoff)
- 4.Command {CMD0} : Send from Host to Device (Host respond system time to device)

ps : 1.Device will change output data from {DATA0} to {REQ0} after read {CMD} from external system
 2.The character position in the string does not contain a comma

1. {REQ0} Data format/example						
Field	Parameter	Value	Data Type	String Length	Position	Description
1	Header+CMD	{REQ0}	String	5 Byte	1-5	Header+Command code
2	Sequence ID	01 ~ 20	String	2 Byte	7-8	MY-TR = 1 - 8, MY-TR5 = 1 - 20
3	Job ID	00 ~ 20	String	2 Byte	10-11	MY-TR = 1, MY-TR5 = 1-20,Default=0
4	Device ID	001 ~ 255	String	3 Byte	13-15	Device index number arranged in the same assembly line (or workstation) (CTDS:1-255 , MCTDS5:1-99)
5	Tool SN	20 Byte	String	20 Byte	17-36	Screwdriver serial no. Less than 20 Bytes ,fill the underline" "
6	Device SN	20 Byte	String	20 Byte	38-57	Device serial no. Less than 20 Bytes ,fill the underline" "
7	Device Operation Mode	0-3	String	1 Byte	59	Mode : 0 : ADV (Connection mode), 1 : STD (Standalone Mode), 2 : ALI (Alignment mode) , 3 : SET (Setting mode)
8	Sequene Control Mode	0-1	String	1 Byte	61	0 : Sequence control mode 1 : Skip sequence mode
9	Setting Status	0-1	String	1 Byte	63	Setting status (Received command executed status) 0 : fales, 1 : success
10	Select Tool	01-09	String	2 Byte	65-66	Selected Tool (Current activated screwdriver)
11	Program Unit	01-99	String	2 Byte	68-69	Selected Unit Program
12	Device Type	0-3	String	1 Byte	71	Device type (0: 1.7x MY-TR,1: 2.0 MY-TR, 2: MY-TR5, 3: WSCBSN)
13	Tool Connect & Keylock	0000000000(10 Byte)	String	10 Byte	73-82	Screwdriver connection status and Keylock state (1: Connect, 0: Not connect) (Byte 1-9 indicate screwdriver connected or disconnected to controller from right to left order, byte 10th is keylock state)
14	Device Version	0.000-9.999	String	5 Byte	84-88	Device firmware version
15	Tool Version	0.00-9.99	String	4 Byte	90-93	Screwdriver firmware version
16	Tool Enable/Disable Status	0-1	String	1 Byte	95	Screwdriver status (0: Disable, 1: Enable)
17	Tool Stop Status	0-9,A-J	String	1 Byte	97	Tool Stop Status (0: None, 1:NS, 2:AS, 3:E3, 4:E4, 5:E5, 7:E7, 8:E8, 9:BS, A:EPC, B:ESC, C:ES, D:Er, E:C1, F:C2, G:C4, H:C5 I:ESD J:EA) EA has an abnormal communication in CTDS 1.7X version. The appearance of EA in MCTDS5 means bad RS485 communication. C3 appears for AS so it will send 2. BS only appear on the MCTDS5.
18	Device extend function	0-1	String	1 Byte	99	Device extend function code (0: None, 1:Clear Batch)
19	Screw count	000-250/001-250	String	7 Byte	101-107	Remaining screws/Total screws
20	Year	0001-9999	String	4 Byte	109-112	Year
21	Month	01-12	String	2 Byte	114-115	Month
22	Date	01-31	String	2 Byte	117-118	Date
23	Hour	00-23	String	2 Byte	120-121	Hour(24 hours)
24	Minute	00-59	String	2 Byte	123-124	Minute
25	Second	00-59	String	2 Byte	126-127	Second
26	Check Sum	0000-9999	String	4 Byte	129-132	
27	Key Code	0000-9999}	String	5 Byte	134-138	Key Code+Tail
28						ASCII code LF
29						ASCII code CR
Remark Item 1 to 27 are separated by "," (ASCII 0x2c)						

2. {REQ1} Barcode format/example						
Field	Parameter	Value	Data Type	String Length	Position	Description
1	Header+CMD	{REQ1}	String	5 Byte	1-5	Header+Command code
2	Barcode	1-30 Byte	String	30 Byte	7-36	Barcode data
3	Year	0001-9999	String	4 Byte	38-41	Year
4	Month	01-12	String	2 Byte	43-44	Month
5	Date	01-31	String	2 Byte	46-47	Date
6	Hour	00-23	String	2 Byte	49-50	Hour(24 hours)
7	Minute	00-59	String	2 Byte	52-53	Minute
8	Second	00-59	String	2 Byte	55-56	Second
9	Check Sum	0000-9999	String	4 Byte	58-61	
10	Key Code	0000-9999}	String	5 Byte	63-67	Key Code+Tail
11						ASCII code LF
12						ASCII code CR
Remark Item 1 to 10 are separated by "," (ASCII 0x2c)						

3. {DATA0} Data format/example						
Field	Parameter	Value	Data Type	String Length	Position	Description
1	Header+CMD	{DATA0}	String	6 Byte	1-6	Header+Command code
2	Device Type	0-3	String	1 Byte	8	Device type (0: 1.7x MY-TR, 1: 2.0 MY-TR, 2: MY-TR5, 3: WSCBSN)
3	Device ID	001-255	String	3 Byte	10-12	Device index(Exclusive in the same AMS system) (CTDS:1-255 , MCTDS5:1-99)
4	Tool SN	20 Byte	String	20 Byte	14-33	Screwdriver serial no. Less than 20 Bytes ,fill the underline" "
5	Device SN	20 Byte	String	20 Byte	35-54	Devicer serial no. Less than 20 Bytes ,fill the underline" "
6	Device Count	000000001-999999999	String	10 Byte	56-65	Device accumulated shutoff count after poweron
7	Program unit	01-99	String	2 Byte	67-68	Selected Program unit
8	Select Tool	01-09	String	2 Byte	70-71	Selected Tool (Activated screwdriver)
9	Torque	0000.0000-0550.0000	String	9 Byte	73-81	Shutoff troque
10	Torque unit	kgf.cm, N.m, lbf.in, kgf.m	String	6 Byte	83-88	Troque unit Less than 6 Bytes , fill the bottom line" "
11	Fastening time	0000.0000-0009.9990	String	9 Byte	90-98	Fastening time(ms)
12	Fastening thread	0000.0000-0999.9000	String	9 Byte	100-108	Fastening thread
13	Screw count	000-250/001-250	String	7 Byte	110-116	Remaining screws/Total screws
14	INC/DEC	INC,DEC	String	3 Byte	118-120	Batch Mode:Increase , Decrease
15	Status	OK,NGT,NGQ,NGC,OKALL,REV	String	5 Byte	122-126	Fastening status OK:Each time when the fastening is complete. NGT: stop time is earlier than L/later than H. NGQ: stop torque is less than L/more than H. NGC: stop number of turns is less than L/more than H. OKALL:Each time when a batch is complete. REV:Reverse Less than 5 Bytes ,fill the underline" "
16	Device Operation Mode	0-3	String	1 Byte	128	Mode: 0 : ADV (Connection mode), 1 : STD (Standalone Mode), 2 : ALI (Alignment mode) , 3 : SET (Setting mode)
17	Tool Stop Status	0-9,A-J	String	1 Byte	130	Tool Stop Status (0: None, 1:NS, 2:AS, 3:E3, 4:E4, 5:E5, 7:E7, 8:E8, 9:BS, A:EPC, B:ESC, C:ES, D:Er, E:C1, F:C2, G:C4, H:C5 I:ESD J:EA) EA has an abnormal communication in CTDS 1.7X version. The appearance of EA in MCTDS5 means bad RS485 communication. C3 appears for AS so it will send 2. BS only appear on the MCTDS5.
18	Torque Filter	0-250,255	String	3 Byte	132-134	Torque filter (0:No filter,1-250 : Filter count,255:Unlimited Filter) MY-TR 2.124 and MY-TR5 2.005 version add infinite filtering and modify 20 times to
19	Pre-filtering torque	0000.0000-0550.0000	String	9 Byte	136-144	Pre-filtering torque This field is only available for MY-TR 2.124 and MY-TR5 2.006.

20	Current value	0000-65535	String	5 Byte	146-150	Current value This field is only available for MY-TR 2.124 and MY-TR5 2.006.	
21	Year	0001-9999	String	4 Byte	152-155	Year	
22	Month	01-12	String	2 Byte	157-158	Month	
23	Date	01-31	String	2 Byte	160-161	Date	
24	Hour	00-23	String	2 Byte	163-164	Hour(24 hours)	
25	Minute	00-59	String	2 Byte	166-167	Minute	
26	Second	00-59	String	2 Byte	169-170	Second	
27	Check Sum	0000-9999	String	4 Byte	172-175		
28	Key Code	0000-9999}	String	5 Byte	177-181	Key Code+Tail	
29						ASCII code LF	
30						ASCII code CR	
Remark		Item 1 to 28 are separated by "," (ASCII 0x2c)					{DATA0, }Total:181 Byte,28 Filed

4. {CMD0} Data format/example							
{CMD0,0,0,0,0,0,0,2018,09,03,18,45,19,2112,7550}							
Field	Parameter	Value	Data Type	String Length	Position	Description	
1	Header+CMD	{CMD0}	String	5 Byte	1-5	Header+Command code	
2	Device Name	0-1	String	1 Byte	7	Device Name(0: AMS, 1: DAS)	
3	unused	0	String	1 Byte	9	unused	
4	unused	0	String	1 Byte	11	unused	
5	unused	0	String	1 Byte	13	unused	
6	unused	0	String	1 Byte	15	unused	
7	unused	0	String	1 Byte	17	unused	
8	Year	0001-9999	String	4 Byte	19-22	Year	
9	Month	01-12	String	2 Byte	24-25	Month	
10	Date	01-31	String	2 Byte	27-28	Date	
11	Hour	00-23	String	2 Byte	30-31	Hour(24 hours)	
12	Minute	00-59	String	2 Byte	33-34	Minute	
13	Second	00-59	String	2 Byte	36-37	Second	
14	Check Sum	0000-9999	String	4 Byte	39-42		
15	Key Code	0000-9999}	String	5 Byte	44-48	Key Code+Tail	
16						ASCII code LF	
17						ASCII code CR	
Remark		1.Item 1 to 15 are separated by "," (ASCII 0x2c) 2.Reply to CMD0 when the time is inconsistent or repeat {DATA0}					{CMD0, }Total: 48Byte,15 Filed

Communication interface :			
RS-232C 9 Pin Female (DCE) to PC or PLC (DTE)			
Connection RS232 :	1.Barcode scanner	Connection method:MY-TR	Connection method:MY-TR5
PORT1			
PORT2			
Remark ※When the trip information (DATA0) is continuously transmitted, it can be judged by the field six *			

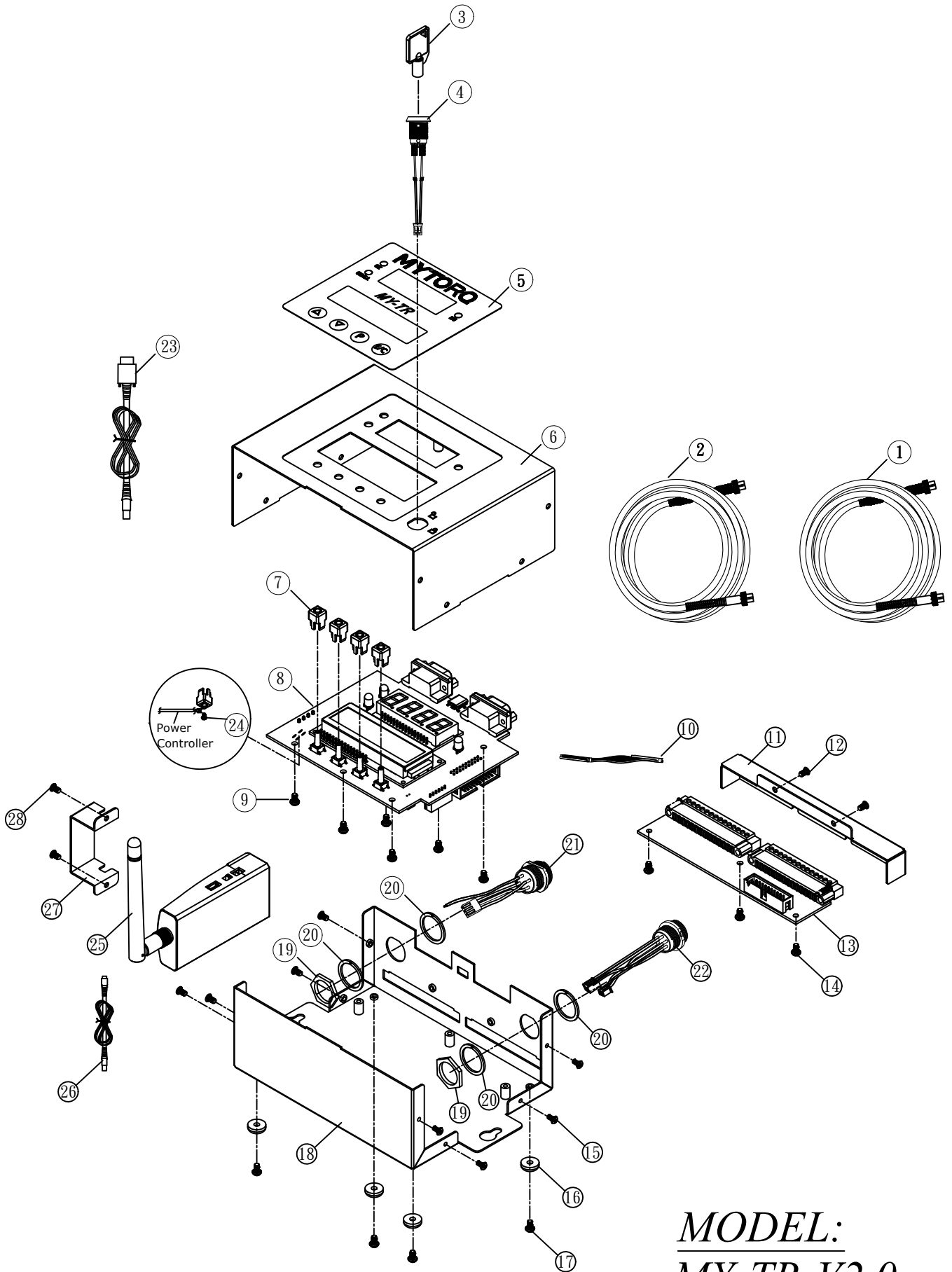

MODEL:
MY-TR-V2.0

CUSTOMER	DWG NAME	PRODUCTION NO.			
ITEM NO.	DWG NO.	 THIRD ANGLE PROJECTION.			
TITLE:	MATERIAL			SHRINK	
	DES. BY			DATE	
	CHKD. BY			DATE	
	APPD. BY	DATE	UNIT	SCALE	SHT NO.
					OF SHTS.

No.	PARTS NO.	PARTS NAME-E	PARTS NAME-C	Q'ty
1	AA50001-139N	CORD ASSEMBLY (BC6Pin) 3M	連接線 BC6PIN 3M隔離線灰色	1
2	AA50005-B6P-7-2	CORD ASSEMBLY (BC6Pin& 4Pin) 2M	連接線 BC6P轉4P 2M	1
3	P11404-6	Key (1506)	鑰匙 (1506)	1
4	P11404-8	Key Switch ASS'Y	鑰匙開關半成品	1
5	YTM0173-1	Sticker-Model	面板貼紙	1
6	CAA10003-1	Housing-Upside	外殼上蓋	1
7	C50226-1	Button	按鍵開關蓋	4
8	EG31541-1	PCB	機板成品 電流偵測扭力顯示	1
9	CH20505-6	Srew M3*5mm	螺絲 圓頭 M3*5mm	6
10	E31726-1	20Pin Plug	20P 雙排插頭含線	1
11	C50217-2	Terminal Cover	端子保護蓋	1
12	CH30222-1	Srew M3*0.5P*5L I	螺絲 M3*0.5P*5L I	2
13	EG31538-3	PCB-IO	機板成品-IO	1
14	CH20505-6	Srew M3*5mm	螺絲 圓頭 M3*5mm	3
15	CH30222-1	Srew M3*0.5P*5L I	螺絲 M3*0.5P*5L I	8
16	CH20110	Rubber Shim	腳墊	4
17	CH20504-0	Srew M3*5mm NI	螺絲 傘頭 3*5mm NI	4
18	CBA10003-1	Housing-Underside	外殼下蓋	1
19	X10068	Bolt	螺帽	2
20	X10067	Washer	墊片	4
21	PZ50180-5	Connector (4Pin)	插座半成品-4Pin	1
22	PZ50165-23	Connector (BC6Pin)	插座半成品-BC6Pin	1
23	P11307	USB Converter	USB 轉換器	1
24	CH80506C	Srew-Power Controller Grounding Means	螺絲-電源接地線用	1

P11306C-1				
No.	PARTS NO.	PARTS NAME-E	PARTS NAME-C	Q'ty
25	P11306B-1	Transmitter	傳輸器 無線	1
26	AA00001	CORD ASSEMBLY-L-Cable	連接線-L-Cable	1
27	P10906-1	Fixed seat Plate	固定環	1
28	CH30222-1	Srew M3*0.5P*5L I	螺絲 M3*0.5P*5L I	2